

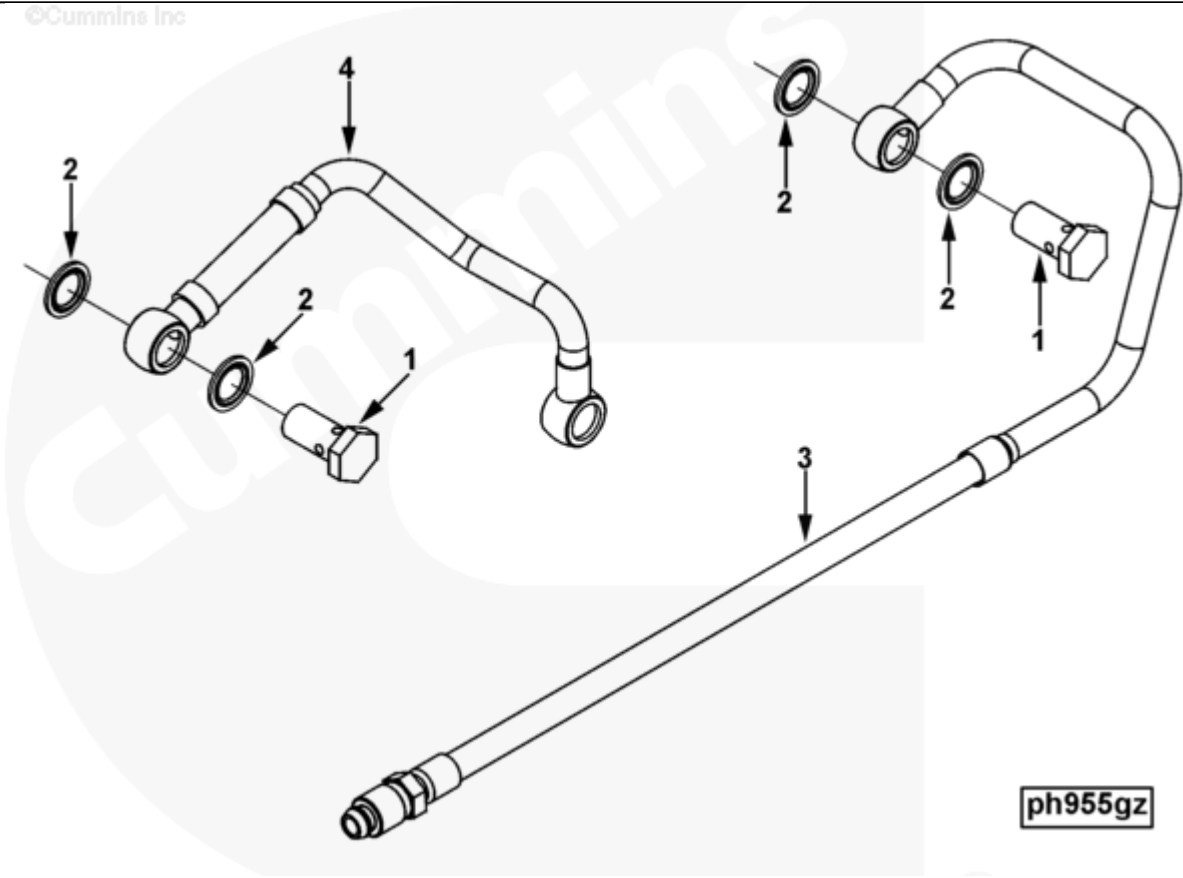

## Parts Catalog - Option Detail

Electronic Parts Catalog - Option Detail				
Option	Group	Graphic	Film Card	Date
PH9172-01	06.03	ph955gz	Z	05-AUG-06
<b>Engines</b>	6C8.3, C GAS PLUS CM556, G8.3, G8.3 CM558, GTA8.3 CM558, ISC CM2150, ISC CM554, ISC CM850, ISC8.3 CM2250, ISC8.3 G CM2180 C101, ISL CM2150, ISL CM554, ISL CM850, ISL G CM2180, ISL8.9 CM2150 L110, ISL8.9 CM2880 L112, ISL9 CM2150 SN, ISL9 CM2250, ISL9 CM2350 L101, ISL9 CM2350 L111, ISLE4 CM850, L GAS PLUS CM556, L8.9, L8.9 L121, L8.9G CMOH2.0 L125B, L9 CM2350 L116B, L9 CM2350 L119B, L9 CM2350 L120C, L9 CM2350 L123B, L9.3 L105, L9.5 L117, L9N CM2380 L124B, QSC8.3 CM2250, QSC8.3 CM2880 C102, QSC8.3 CM554, QSC8.3 CM850(CM2850), QSL9 CM2250, QSL9 CM2250 L115, QSL9 CM2350 L102, QSL9 CM2350 L107, QSL9 CM2350 L118, QSL9 CM2350 L122, QSL9 CM554, QSL9 CM850(CM2850), QSL9 G CM558, QSL9 M CM2250 L106, QSL9.3 CM2880 L113			



SMALL | MEDIUM | LARGE

Cart	Ref No	Part Number	Part Description	Required	Remarks
View My Cart					
		PH9172-01	Engine Control Module Plumbing		<a href="#">MR - PLUMBING, ENG CNT MODULE...</a> (More)
					Engine Family: C Series
					Gear Pump Inlet Port

					Location:
					Centerline of Crank to
					Inlet Centerline
					(mm): 206
					Centerline of Engine to
					Inlet Centerline
					(mm): 337
					Front Face of Block to Inlet
					Centerline
					(mm): -210
					ECM Outlet Location:
					Centerline of Crank to
					Outlet Centerline
					(mm): 166
					Centerline of Engine to
					Outlet Centerline
					(mm): 222
					Front Face of Block to
					Outlet Centerline
					(mm): -587
					Fuel Connection Outlet Port
					Location:
					Centerline of Crank to
					Outlet Centerline
					(mm): 403
					Centerline of Engine to
					Outlet Centerline
					(mm): 40
					Front Face of Block to

					Outlet Centerline
					(mm): -617.5
					Unique Characteristics: Fuel
					Lines Bypass the ECM Cooler
<input type="checkbox"/>	1	<a href="#">3903035</a>	Banjo Connector Screw	2	M12 X 1.50 X 24.
<input type="checkbox"/>	2	<a href="#">3963990</a>	Sealing Washer	4	M12.
<input type="checkbox"/>	3	<a href="#">4935138</a>	Fuel Supply Tube	1	
<input type="checkbox"/>	4	<a href="#">4935139</a>	Fuel Supply Tube	1	

© 2019 Cummins Inc., Box 3005, Columbus, IN 47202-3005 U.S.A.  
 Terms of Use and Disclaimers | Recommended System Requirements  
 Need Assistance? Please click on the Contact Us button in the top right corner of any page.